

# ELECTRO\_COUP

Electrification of heating and mobility: Socioeconomic impacts of non-ETS policies with sector coupling and sectoral linkages

## WORKING PAPER 3

### Bottom-up modelling

**Authors:** Andreas Müller, Kurt Kratena

**Vienna, September 2022**

ELECTRO\_COUP

**Duration:** 1<sup>st</sup> October 2021 – 31<sup>st</sup> March 2023

**Lead:** Centre of Economic Scenario Analysis and Research (CESAR)

**Partner:** Westfälische Wilhelms-Universität Münster (WWU) Münster, Lehrstuhl für Mikroökonomik, insbes. Energie- und Ressourcenökonomik

**Kontakt:** Kurt Kratena (kurt.kratena@cesarecon.at)

powered by  Klimaenergiefonds

This project is funded by the Austrian Climate and Energy Fund as part of the „Austrian Climate Research Programme – ACRP 13th Call“.

**Content:**

Introduction .....	3
Modelling heating demand: the Invert model environment .....	3
Database of technologies and efficiency measures .....	3
Calculation of energy needs and demand.....	3
Determination of investment timing .....	3
Three different model types.....	3
Modelling the annual efficiency of heat pumps in the Invert model.....	5
Modelling the refurbishment options in the Invert model.....	7
Modelling transport demand: A physical bottom-up perspective .....	8
Private vehicle purchases and stocks .....	8
Technology and fuel consumption for private vehicles.....	9
References.....	11

## Introduction

In the ELECTRO\_COUP project, the macroeconomic input-output (IO) model LEEM (Linked Energy-Economy Model) comprises the energy system from final energy demand to energy transformation and production (see ELECTRO\_COUP Working Paper 1 for a short documentation of the model). In order to have a more detailed view of drivers, barriers and possibilities for decarbonization, we linked the LEEM model with (i) the bottom-up Invert Model, focusing on energy services for space heating and hot water, and (ii) the bottom-up dataset from the NEMO model for private and freight transport in Austria.

## Modelling heating demand: the Invert model environment

The Invert modelling environment is a bottom-up techno-economic tool to analyse space heating, hot water generation and space cooling in the building stock. It is designed to quantitatively evaluate the effects of different framework conditions on total energy demand, energy carrier and technology mix, CO<sub>2</sub> emissions and costs. Such framework conditions include price scenarios for energy carriers, cost scenarios for technologies and efficiency measures, different settings of economic and regulatory incentives, consumer behaviour, climate change and resource potential restrictions. The model is based on a highly disaggregated description of the building stocks in the different analysis regions. This includes the type of a building, age, state of renovation, existing heating systems, user structure as well as regional aspects such as availability of energy infrastructure for gas or district heating. In the analyses usually, both residential and tertiary buildings, are covered.

### Database of technologies and efficiency measures

The model uses an extended database of technologies and efficiency measures containing their technical and economic characteristics. On the one hand this integrates currently applied and potential future technologies for the supply of space heating, hot water and space cooling, including on-site solar thermal and PV generation as well as the heat distribution systems in the building. On the other hand, a large set of options for building shell refurbishment and heat recovery systems is considered for decreasing energy needs in the buildings.

### Calculation of energy needs and demand

In the "Energy module" of Invert the energy needs, final energy demand and delivered energy for space heating, hot water generation and space cooling are calculated. The module applies a quasi-steady state monthly energy balance approach according to EN13790. Furthermore, these standard calculations are adjusted to take into account the observed differences between calculated and measured energy demand using a disaggregated service factor approach.

### Determination of investment timing

Based on age and lifetime distributions of buildings and their different components like shell elements and installed technologies, the timing of investment decisions in the building stock is determined in the "Service lifetime module". This includes building demolition, new construction, refurbishment activities and supply system change.

### Three different model types

For calculating scenarios of potential future states of the building stocks three different modules can be applied, each representing a different model type:

- **Invert/EE-Lab** applies a combination of a discrete choice approach and technology diffusion theory to simulate energy-related investment decisions in the buildings over a defined analysis period.
- **Invert/Opt** uses an optimisation approach to identify the least-cost combination of investment decisions in all buildings of an analysis area under given conditions and constraints until a defined future year.
- **Invert/Accounting** is designed to quantify the effects of exogenously defined settings in a defined future year e.g. related to renovation rates or supply system shares.

Fig. 1 shows the structure of Invert when applying the EE-Lab version of the tool.

Fig. 1. Overview of the structure of Invert when applying the EE-Lab version

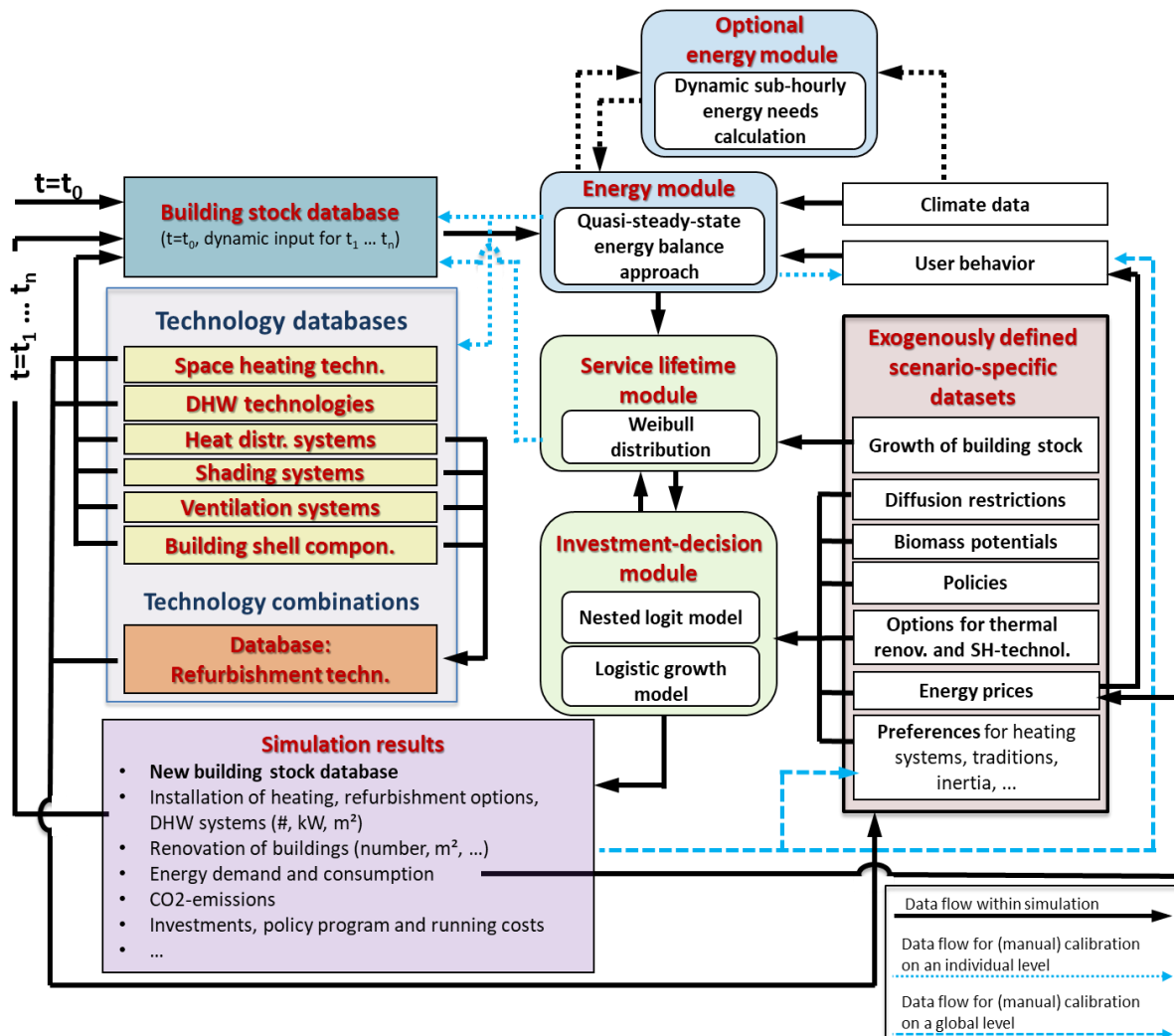

In this project, we apply a middle-ground between the investor agent driven EE-Lab approach and the accounting approach. For this, we define the overall renovation activities (related to energy needs) exogenously and set policy and energy costs-related parameters so that we achieve a predefined scenario development. It is important to note that the scenarios need to be seen as “what-if” scenarios, as we do not explicitly implement all current and proposed policy measures. Furthermore, we do not explicitly let the investor agents optimize their decisions with respect to implemented energy prices.

## Modelling the annual efficiency of heat pumps in the Invert model

Electric-driven heat pumps are generally expected to play an important role in the decarbonization of the low-temperature heat demand in buildings. Their main advantage as compared to other technologies is their ability to utilize the energy present in the environment to supply heat at a temperature level that exceeds that of the environment using the exergy content of electricity.

The efficiency of heat pumps strongly depends on the temperature difference between the heat source (ambient heat) and the energy sink; the loss-free theoretical efficiency is described by the Carnot efficiency. In our case, the temperature source most commonly is either the outdoor air (air-source heat pumps) or shallow geothermal heat and is for space heating purposes typically in a temperature range of -10 (air-source heat pump on a cold day) to +10 degrees (typical ground or air temperature in autumn). The temperature level of the heat sink is either the hot water tapping temperature, which might be in the range of 45-55°C or the supply line temperature level of the heating system. The latter parameter depends strongly on the type of heat radiation system and can be as low as 30°C if floor or wall heating systems with a large heat radiation surface area are used but can be as high as 75°C if the heat radiation surface area is low as compared to the heat demand of the building.

The typical heat supply temperature applied in buildings is a function of the building's age (and refurbishment status). First, older buildings tend to have a higher per-square meter heat demand than more recent buildings, second since floor and wall heating systems tend to be more costly (and complex) than regular radiator-based heating systems and were not applied as commonly in previous decades. Thus, as a rule of thumb, it can be assumed that heat pumps are more efficient in more recent or new buildings and less efficient in older buildings with high energy needs.

The current debate on the future role of heat pumps in the building sector circles around this efficiency argument. While proponents of a high diffusion of heat pumps argue stress the ability of heat pumps to provide heat also at high-temperature level at efficiency levels that by far exceed that of combustion-based systems such as gas boilers, opponents argue that scenarios with a high heat pump diffusion require deep refurbishment activities and will therefore become more costly than scenarios using combustion-based systems along with carbon neutral energy carriers either biomass based or derived by a PtG (power-to-gas) or PTL (power-to-liquid).

In the Invert model, the annual average efficiency is not defined by a single parameter but is modelled as a function of the average heat supply temperature of heat distribution system in buildings and in the case of the air-source heat pumps on the average monthly ambient air temperature. Based on the system boundaries according to JAZ4 definition (see Fig. 2), we assume that heat pumps deliver their seasonal coefficient of performance if the heat is distributed at a supply line temperature level of 35 °C (for hydronic heating systems).

Fig. 2. System boundaries of different definitions for the annual efficiency of heat pumps

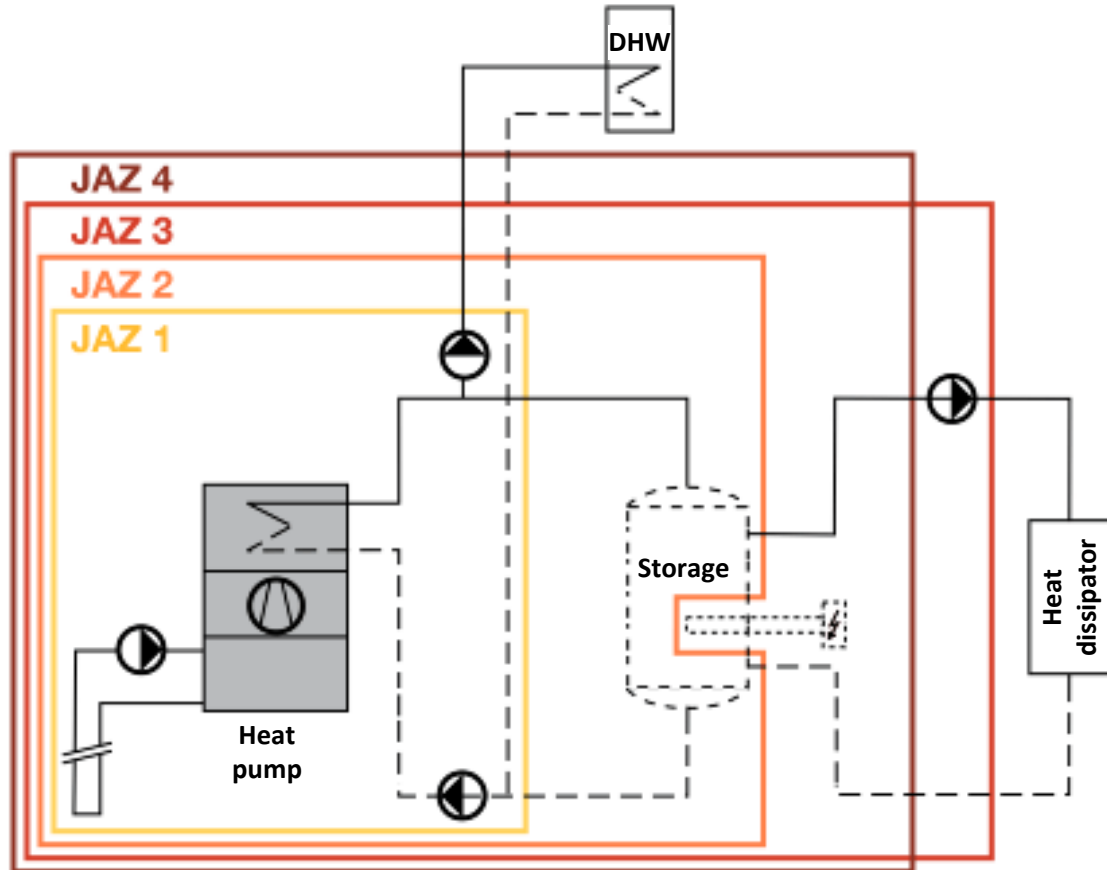

Source: <http://www.jahresarbeitszahlen.info/index.php/jahresarbeitszahl/systemgrenzen>, translated from German

If the supply line temperature is higher than 35 °C, the efficiency decreases linearly by 35% for air-sourced and 25% for brine-water based heat pumps if the annual weighed average supply line temperature increases to 55 °C. Above the temperature level, the efficiency drops non-linearly using an elasticity of 1.2 (see Fig. 3).

Fig. 3. Implemented annual efficiencies of heat pumps

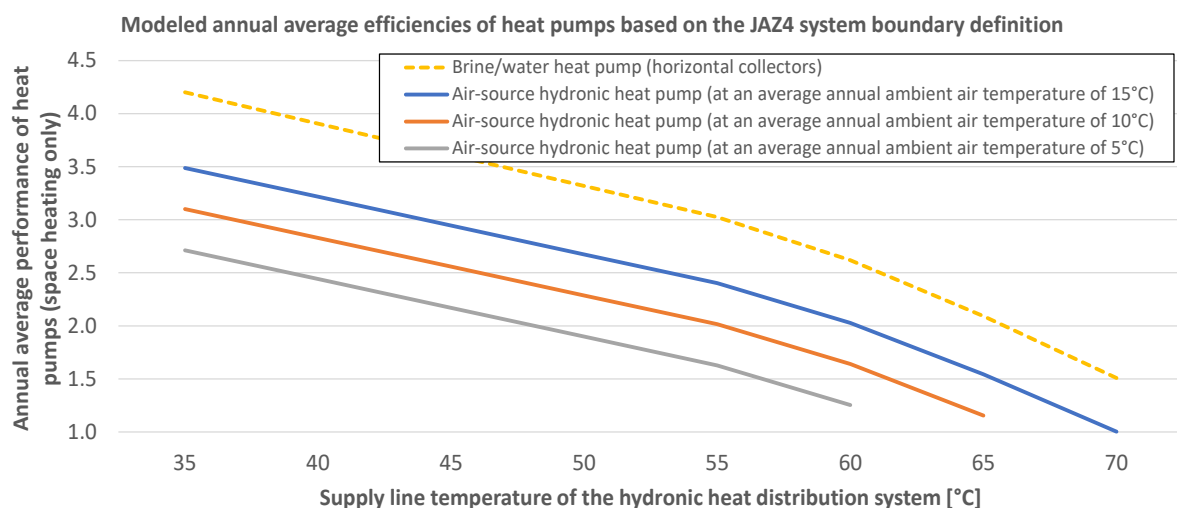

Regarding the heat distribution system and their average annual supply line temperature, we assume that older buildings use heating systems, which were designed for higher temperature levels, and that the design temperature dropped if buildings were constructed since the

1970ies. Based on our assumptions, buildings constructed before 1970 are equipped (if a building or apartment central heat distribution system is installed), with a distribution system that is designed to deliver the design heat load of the building at the winter design temperature conditions at a temperature level of 70-90°C, which leads to an average supply line temperature of about 58-70°C. For buildings constructed between 1970 and 2000, a design temperature of 55-60°C (leading to an average annual temperature of about 48-52°C) has been chosen. For more recent buildings, we assumed an average design temperature of 40-50°C (annual average temperature of 38-47°C). In addition, we defined a lower limit for the supply line temperature depending on the specific energy needs for space heating. Here consider that the average supply line temperature can fall below 40°C only if the annual energy needs for space heating are less than 70 kWh/m<sup>2</sup> and must be above 50°C, if the energy needs exceed 130 kWh/m<sup>2</sup><sup>1</sup>.

If a building gets refurbished within the simulation, the Invert model estimates a new, reduced average supply temperature that would be sufficient to heat the building since the heat load of the building has been reduced by energy efficiency measures, while the heat dissipator area (radiator area) did not (according to our assumptions). To estimate the effect, we implemented a simplified calculation procedure for the concept of logarithmic excess temperature (see Müller, 2015) along with the assumption, that buildings utilize 80% of the possible temperature decrease.

### Modelling the refurbishment options in the Invert model

In order to reduce the energy needs of buildings, refurbishment packages are defined in the model. In the current setting, we allow one maintenance option, which doesn't improve the energy performance, and three refurbishment options: shallow, medium, and deep. We defined the settings as such, that the energy needs of refurbished buildings if choosing the medium option, are in line with the Austrian energy performance standards for deep refurbishment (using the more ambitious HWB\* and not the fGEE-certification methodology). In order to achieve the demanded target, a mixed-integer optimization model chooses the optimal level of insulation thickness for a) opaque vertical surface areas (façade), b) upper ceiling c) floor, d) optimal type windows and c) ventilation system with heat recovery, so that the energy target can be achieved in a cost-optimal manner.

---

<sup>1</sup> We implemented the following equations for the lower limit of the heat supply line temperature:  $T_{supply, lower\_limit} = \min(60^{\circ}\text{C}, \max(0, en_{sh} - 50)/10 * 20^{\circ}\text{C} + 35^{\circ}\text{C})$ , where  $en_{sh}$  denotes the annual energy needs for space heating per square meter of heated gross floor area in [kWh/m<sup>2</sup>].

## Modelling transport demand: A physical bottom-up perspective

The NEMO model<sup>2</sup> has been constructed and is commercially marketed by the Technical University of Graz. It uses a physical bottom-up dataset for private, public and freight transport, covering vehicle stocks by drive, transport services (person-km and ton-km of freight), energy use and air emissions. These data are disaggregated for the different drives of private transport (gasoline, diesel, electric and other (CNG)), different duty vehicles (light and heavy), and different modes of public passenger as well as freight transport (rail, bus, ship, flight and other public (subway, etc.)).

In this study, not the full NEMO model has been used, but only the bottom-up dataset from 1990 to 2021, which has been combined with other data sets. A small bottom-up model has been constructed, comprising functions for the different vehicle stocks and the development of energy intensities. The other datasets cover population and vehicle stock data from 1950 on and data from a recent “baseline” (WEM = “with existing measures”) scenario.

### Private vehicle purchases and stocks

A large body of transport research literature deals with saturation of private car ownership in terms of car density per head or by household. Recently, that has been complemented by literature on ‘peak car’, referring to a maximum of car transport or car use. The main methodology for modelling saturation is the Gompertz function (for a recent example, s.: Felis Rota, et al., 2016) that resembles a logistic function for private car density (vehicles per head of population). The properties of the underlying non-linear relationship between population and income on the one side (mostly combined in a per capita income indicator) and the vehicle stock on the other side imply a constant density after having reached the point of saturation and a decreasing income elasticity for vehicle ownership in the long-run (Dargay et al., 2007). The factors leading to ‘peak car’ in the literature are mainly socio-demographic developments like urbanization, public transport supply, behavioural change (less driving licenses per head of population) and others (Walker, 2017 and Sivak, 2013). In a ‘peak car’ model, vehicle density might reasonably decline after having reached the peak, as these factors are still acting on vehicle density.

The data for Austria from 1960 to 2021 show a flattening of the curve of car density with a breaking point at the time of the first oil price shock (1973). Different time series models can be applied to explain the development of this curve, like a flexible saturation model, a Gompertz function or different techniques of extracting trends. A model based on per capita-income could apply a density function of the income elasticity with a flat right tail as in Dargay et al., (2007) plus a linear trend. Estimations for the 1960 – 2021 period with these two parameters yields a negative trend for vehicle purchases. Extrapolating this negative trend with some uncertainty range up to 20240 yields a robust ‘peak car’ around 2030.

For this study, a 3 year-moving average for vehicle density data has been extracted and this smoothed time series has been dampened by a factor of 0.92 from 1974 on for considering the structural break after the first oil price shock. The mean of the growth rate of this smoothed data can then be extrapolated into the future. As figure 3 shows, the smoothed series overestimates the actual data for vehicle density. Nevertheless, the underlying trend would lead to a peak of vehicle density in 2023/24 at about 620 vehicles per 1.000 persons. This is significantly below other estimates in the literature (Felis Rota, et al., 2016 and Dargay et al., 2007), which range from 650 to above 700 vehicles per 1.000 persons.

Extrapolations for vehicle density can be used to calculate vehicle stocks for the period up to 2040, which, in turn, can be converted into annual investment (vehicle purchases in physical units). It must be noted here that the NEMO dataset also covers data on licenses of new cars, which could also be seen as the additions to the existing stock.

---

<sup>2</sup> See [https://www.itna.tugraz.at/assets/files/areas/em/NEMO\\_en\\_2022.pdf](https://www.itna.tugraz.at/assets/files/areas/em/NEMO_en_2022.pdf)



The relationship between stocks and flows is for this study given with the accumulation equation:

$$K_{veh,t} = (1 - depr) K_{veh,t-1} + VEH_{t-1}$$

The capital stock of vehicles ( $K_{veh}$ ) is depreciated by a (constant) depreciation rate  $depr$  and grows via new vehicle purchases  $VEH$ . When  $VEH$  is approached by the NEMO data for new licenses of cars, the depreciation rate  $depr$  becomes exogenous and shows high and implausible volatility. Therefore, the accumulation equation is in this study used for deriving the vehicle purchases  $VEH$  as endogenous, for the historical data as well as for the extrapolation in the scenarios. The depreciation rate has been fixed by assuming a mean lifetime of private cars of 14 years.

Fig. 4. Private car density, 1960-2021

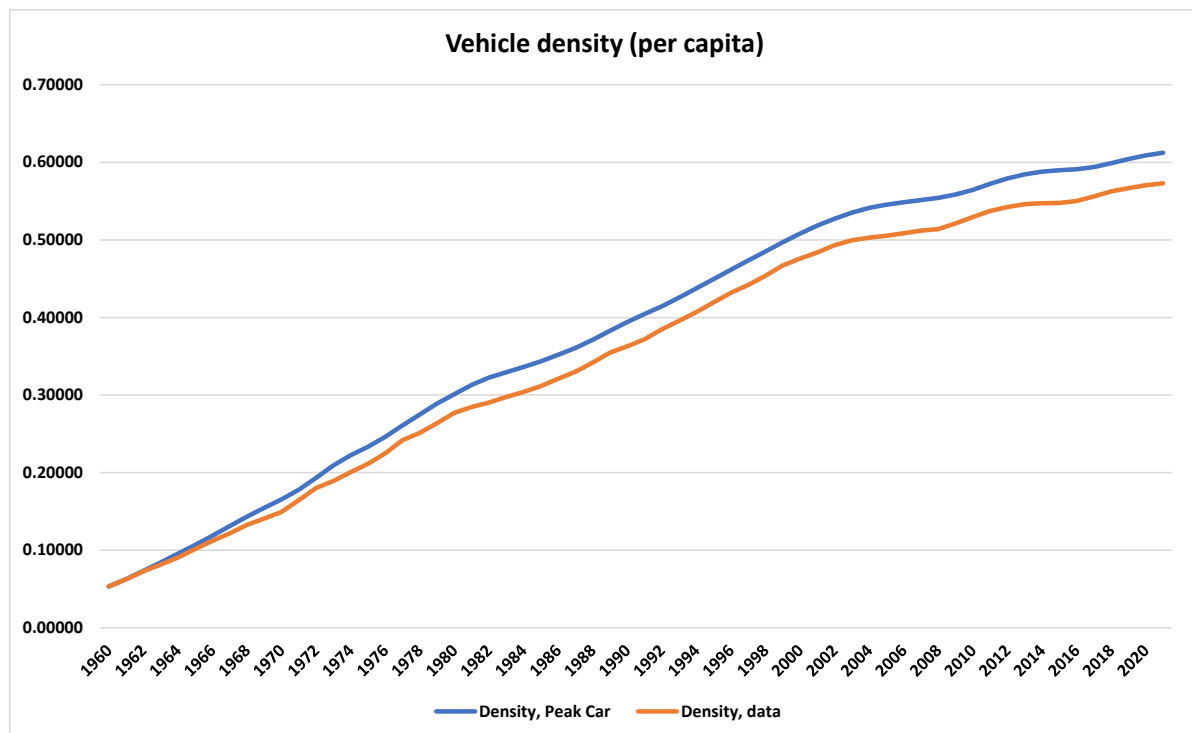

## Technology and fuel consumption for private vehicles

The aggregate purchases of new vehicles need to be split up into purchases of different drives, which is then, together with transport services (person-km and vehicle-km) and average consumption per km (efficiency) the main input for determining energy demand for private transport by type of energy. The main variable that is explained in the part of technology choice is the share of electric drives in aggregate purchases of new vehicles. The purchases of gasoline cars are simply extrapolated with a low trend parameter (between 0 and 1%) and purchases of diesel cars are treated as the residual.

The equation for explaining the share of electric cars is calibrated with parameters taken from the results of models of discrete choice for vehicle purchase. Norway stands out as a country with high shares of electric vehicles in purchases as well as – already – in stocks and several exhaustive empirical studies have been carried out to explain the driving forces behind that (Østil, et al., 2017 and Fridstrøm and Østil, 2018). Models of discrete choice have been estimated and have been used to derive own and cross price elasticities of vehicle demand from model simulations, as 'effective' price elasticities (Fridstrøm and Østil, 2021). These elasticity values have been used for this study to calibrate a simple log-linear function for the share of electric cars in total vehicle purchases which incorporates the properties of the models for Norway.

The equation describes the electric car-share as a function of vehicle prices (fossil (gasoline and diesel) and electric cars), fuel prices (fossil (gasoline and diesel) and electricity) as well as a trend parameter:

$$\ln(VEH_{el,t}) = \text{const.} + b_1 \ln(p_{veh,el}) + b_2 \ln(p_{veh,fo}) + b_3 \ln(p_{fo}) + b_4 \ln(p_{el}) + b_5 t$$

The corresponding parameter values taken from Fridstrøm and Østil (2021) are:

$b_1 = -1$ ,  $b_2 = 0.42$ ,  $b_3 = 0.62$ ,  $b_4 = -0.18$ , and  $b_5 = 0.35$ .

These parameter values imply that a decrease in the price of electric vehicles transforms fully in the share of purchases in the same amount (unit elasticity) and that increases in the electricity price dampen the electrification speed of the fleet, though with a low elasticity value (-0.18). This is relevant, if sector coupling leads to higher power generation from fossil fuels which feeds back again via higher electricity prices (due to higher costs for emission permits). The impact of gasoline and diesel prices is relatively high (elasticity value of 0.62). This is especially relevant in scenarios, where gasoline and diesel prices are continuously increased by rising CO<sub>2</sub> prices.

## References

- Dargay, J., D. Gately, M. Sommer, 2007, Vehicle ownership and income growth, worldwide: 1960 – 2030, *The Energy Journal*, 28(4), 143 – 170.
- Felis Rota, M., J. Moral Carcedo, J. Perez García, 2016, Dual approach for modelling demand saturation levels in the automobile market. The Gompertz curve: Macro versus micro data, *Investigación Económica*, LXXV(296), abril-junio 2016, 43-72.
- Fridstrøm, L., V. Østil, 2018, The demand for new automobiles in Norway – a BIG model analysis, *TØI Report*, 1665/2018.
- Fridstrøm, L., V. Østil, 2021, Direct and cross price elasticities of demand for gasoline, diesel, hybrid and battery electric cars: the case of Norway, *European Transport Research Review*, 13(3), 1-24.
- Østil, V., L. Fridstrøm, K.W. Johansen, Y-Y Tseng, 2017, A generic discrete choice model of automobile purchase, *European Transport Research Review*, 9, 1-20.
- Sivak, M., 2013, Has motorization in the U.S. peaked?, *UMTRI-2013-17*, Transportation Research Institute, University of Michigan, June 2013.
- Walker, J., 2017, Peak car usage: A briefing note, *TRAN3052*, The University of Hongkong, March 2017.